

TAPS

RAIL



COMPANY PRESENTATION

POLAND

94-247 Lodz, Solec 3/5
Phone: +48 (42) 633 86 01
Fax: +48 (42) 650 09 96
e-mail: taps@taps.com.pl
www.taps.com.pl

GENERAL INFORMATION

TAPS started its activity in 1989. It is a private company owned by **Mr. Maciej Kowalski** and it employs 102 persons (for 31/12/2015) with a €4.3 million annual turnover.

TAPS designs, produces and delivers for the railway sector:

- New seats for trains and trams
- Vandal-resistant seats for metro and local mass transport
- Berths and couches for sleeping coaches
- Modernized seats for railway and metro
- Spare parts and accessories for railway, metro, and local mass transport seats
- Fitted carpets and fabric materials for coach interiors

Our company also offers product servicing, especially guarantee and post-guarantee upholstery systems servicing. This activity is based on technologies tested and proven in **TAPS**.

TAPS' products, designed, produced and delivered to Customers from the railway sector, are distinguished by their original design and high quality as well as functional and economical factors desired by Customers. They also comply with Customers' requirements concerning norms and standards connected with fire protection, ergonomics, and durability.

In its over 25 years of production experience, the company has patented an **innovative technology of composite production**. Composites may be used for seats' construction elements as well as interior elements. The technology makes it possible to integrate various sensors and passenger information systems in the production of individual elements.

TAPS' quality management system is confirmed by the **IRIS v2.0** Certificate and the **ISO 9001:2008** Certificate.

Apart from the abovementioned activity on the railway market (90% of sales), the company also specializes in designing, production and installation of seats for theatres, cinemas and auditorium halls (10% of sales).



MAIN CUSTOMERS

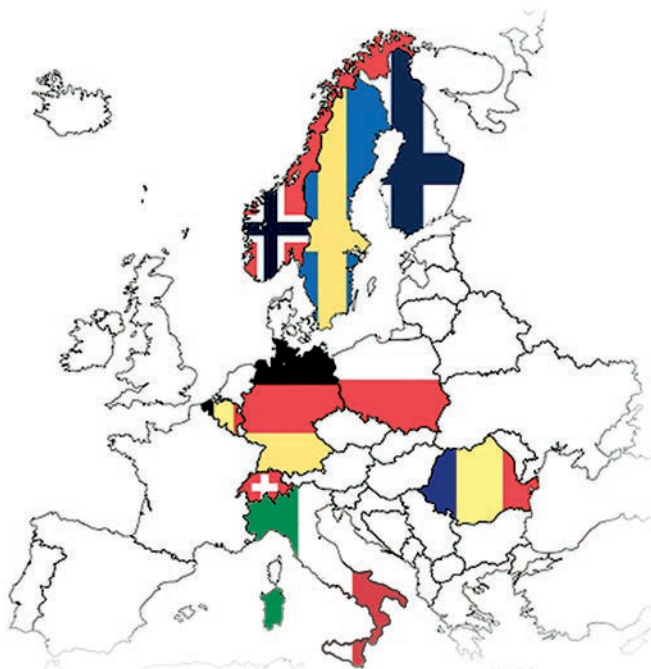

- Alstom Konstal S.A.
- Arlanda Express
- Bombardier Transportation
- Deutsche Bahn AG
- EuroMaint Rail AB
- H. Cegielski S. A. Poznań
- Koleje Mazowieckie – KM Sp. z o. o
- Koleje Dolnośląskie S.A
- METRO Warszawskie Sp. z o.o.
- Newag S.A.
- NSB Rolling Stock AS
- Pesa Bydgoszcz S.A
- PKP Intercity S.A.
- PKP PR Sp. z o.o.
- SJ AB
- SNCB
- STADLER Bussnang AG
- STADLER Pankow GmbH
- Tabor Szynowy – Opole S.A.
- Tramwaje Warszawskie Sp. z o.o.
- Transtech OY
- Wagonmash St. Petersburg
- ZNTK Mińsk Mazowiecki S.A.
- and more...



SALES TO DECEMBER 31ST 2016

377 072	in total
236 291	seats in 1st and 2nd class railway coaches
17 854	berths
36 722	seats in cinemas and theatres
7 200	seats in city busses
19 973	seats in metro
23 320	anti-vandal suburban and regional train seats
26 900	seats in S-Bahn
8 019	seats in trams
912	ferry seats
242	seats in Business Class compartments
168	seats in sport planes and helicopters
383	driver's cab seats



SELECTED NORMS AND STANDARDS

EN 45 545-2:2013, (HL1, HL2, HL3)

flame retardancy

UIC 564-2

flame retardancy

PN K-02502

PN K-02511

PN-84/K-02500

PN-91/K-02501

PN-93/K-02505...

UIC 567-1,2

ergonomics

GruLaSi

ergonomics, strength

UIC 566

strength

DIN 5510-2:2009

flame retardancy

BN 918 434

strength

NF F 31 116

ergonomics

NF F 16 101

flame retardancy

NF F 00 201

vandalproofness

NF F 31 118

vandalproofness

EN 15 085 (CL2)

welding

EN 3834-3 (EN 729-3)

welding



RESEARCH AND DEVELOPMENT

TAPS has its own R&D Department responsible for various tests on the seats and their components and for researching and introducing new technologies. We have our own Laboratory that enables us to conduct ergonomics, fire retardancy, strength and vandalproofness tests on materials and prototypes according to international railway standards UIC 564-2, 566, 567, GulaSI, and EN 45 545-2.

OTHER PROJECTS

Matlev

Cooperation with research centres:



TAPS is also a member of organisations from the railway industry:



ifv Bahntechnik

Interdisziplinärer
Forschungs-
Verbund
Bahntechnik e.V.





CHOSEN CERTIFICATES AND SUPPLIER QUALIFICATIONS

- Polish Register of Shipping (2016, 96/98WE MED)
- Bureau Veritas (2012, IRIS rev 02, 2 June 2012)
- Bureau Veritas (2012, ISO 9001:2008, 2012)
- Bureau Veritas (2009, IRIS rev 01, 24 May 2010)
- TÜV Nord (2014, EN 15 085 CL2/CPC2 and EN ISO 3834-4 (EN 729-4 24 April 2014)
- Stadler Bussnang AG, Stadler Pankow Gmbh - qualified seats supplier
- NSB AS/ Bombardier Transportation Norway (2007, qualified railway seats supplier)
- DB AG (2013, entry to the DB Product Catalogue; 2006, qualified railway seats supplier, category Q1)
- ALSTOM (2005, 2003, qualified railway seats supplier, category B)
- PKP Przewozy Regionalne Sp. z o.o. (2004, Admission Certificate)
- Det Norske Veritas (2004, Certificate ISO 9001:2000)
- SJ/EuroMaintRailAB (2004, qualified railway seats supplier)
- RATP (2002, qualified supplier of modernized, vandalproof railway seats)



DB PRODUCT CATALOGUE

TAPS seats can be found in the DB REGIO AG Product Catalogue.

Innenausstattung der Fahrzeuge

3.4 Dreizeilig freigelegene Sitze 2. Klasse



Innenausstattung der Fahrzeuge

3.1 Dreizeilig freigelegene Sitze 1. Klasse

(zum Teil vorbehaltlich noch ausstehender technischer Freigaben, Ggf. Rücksprache mit DB Regio Marketing erforderlich)



Dokumentation

Produktkatalog DB Regio AG

CONSTRUCTION AND DESIGN

All our products are designed by professional engineers in the Construction and Design Department.

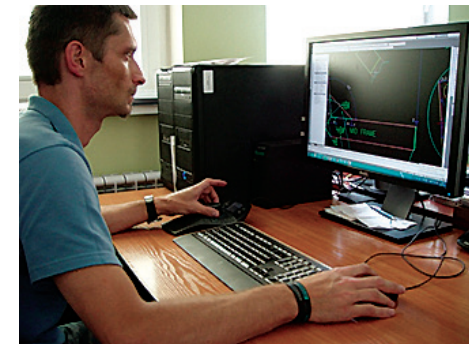
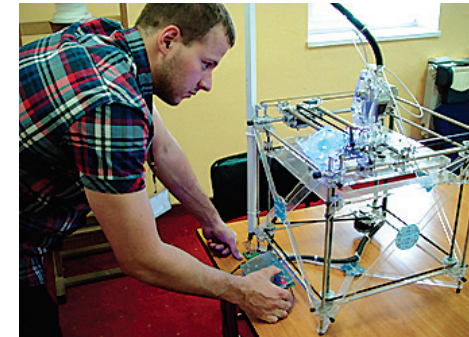
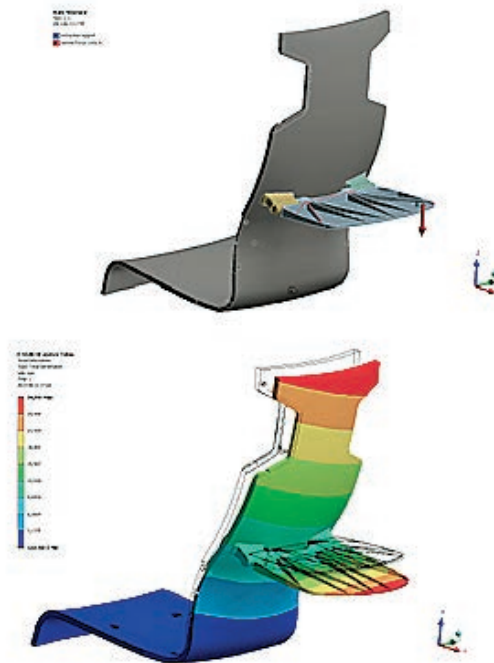
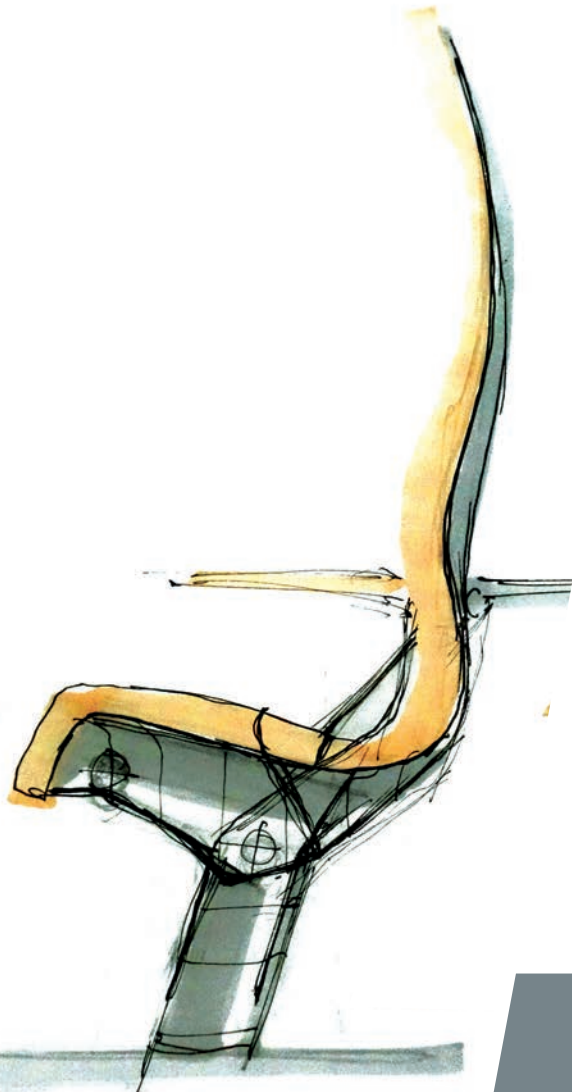



EXHIBITIONS

TAPS exhibits its products at major rail exhibitions: **TRAKO** (all editions) and **InnoTrans** since 2004. Composite technologies, their possibilities and application in seats as well as train interiors are presented at chosen composite exhibitions (**Kompozyt Expo**).



TAPS

RAILWAY SEATS



TAPS

XCR

*regional seat,
newest design
with innovative
ergonomics
ErgoCradle™*



back of the seat



handle

TAPS

XCD

*regional seat,
newest design with
optimal ergonomics*



back of the seat

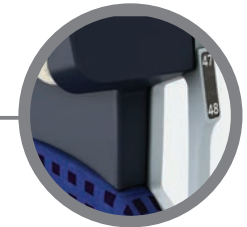

handle

TAPS

XCI 3.2

*compartment seat,
innovative ergonomics
ErgoCradle™*



TAPS

reading
lights

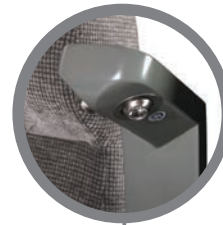

back of the seat



XCR

1ST CLASS SEAT PROTOTYPE

*seat for long-distance trains,
innovative ergonomics
ErgoCradle™*

TAPS



back of the seat



handle



N7B

*regional seat
bistro*

TAPS



back of the seat

power socket

J2B

*regional seat,
light,
composite elements,
aluminium construction*

TAPS

XCDS

*regional seat,
increased comfort*



TAPS



handle
and coat hanger



back of the seat

XCRS

*regional seat 1st
and 2nd class,
newest design with
innovative ergonomics
ErgoCradle™*



foot rest

TAPS



back of the seat

J2

regional seat



TRAM SEAT

*aluminium construction
to be mounted on cantilever
or tram elements (boxes)*



back of the seat

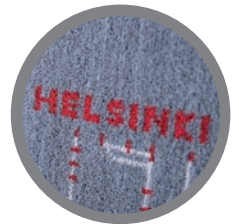

*dedicated
upholstery*

TAPS

TRAM SEAT

*different arrangements
(row, back-to-back, back)
with equipment
(handle, mounting
of support pipe)*

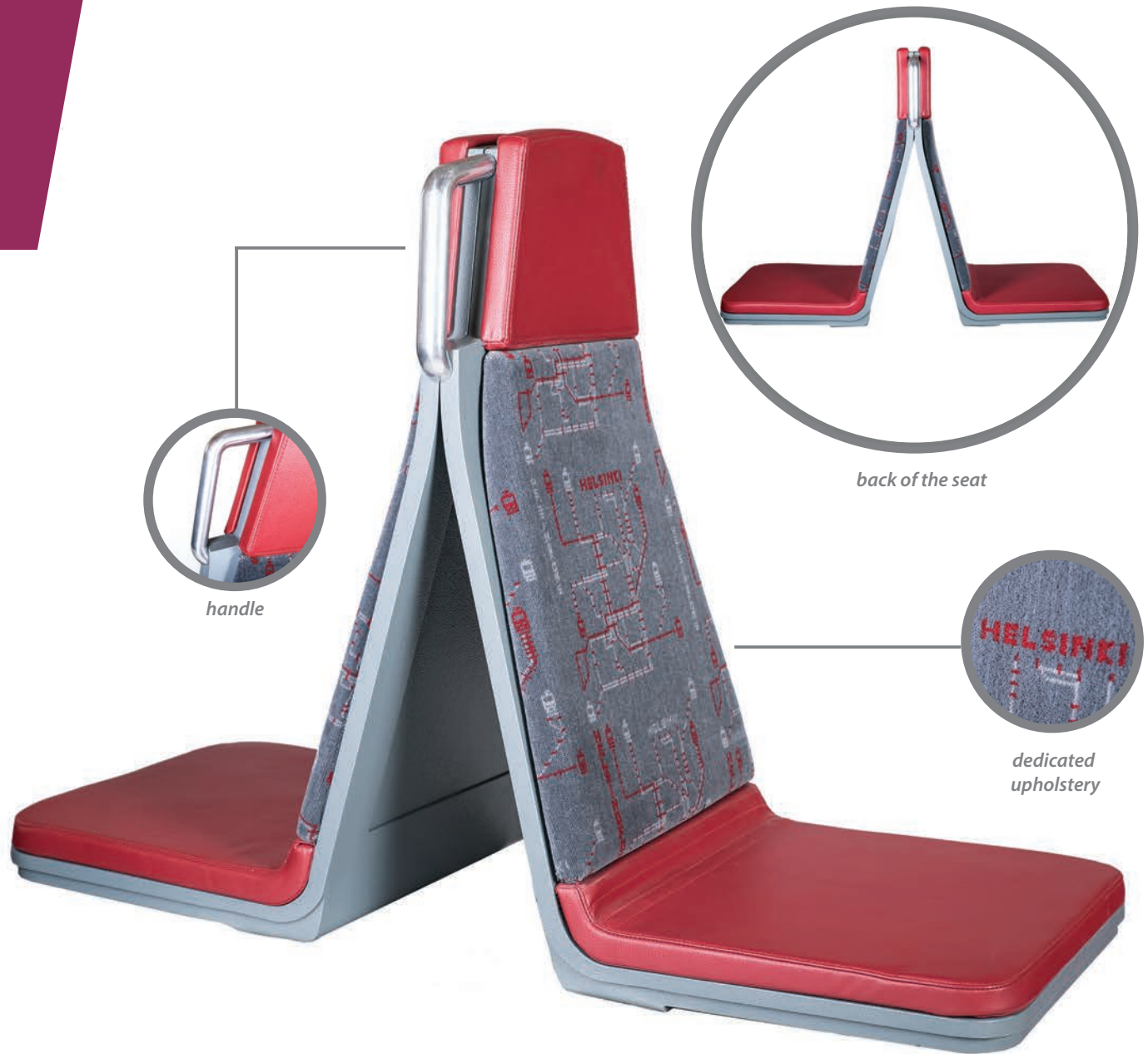

handle



back of the seat

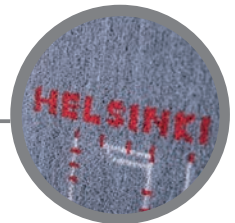

dedicated upholstery

TAPS



TRAM SEAT

*aluminium construction
to be mounted
on cantilever
or tram elements (boxes)*



TAPS



VANDALPROOF SEAT AV METRO

*aluminium construction
with composites
and glass fibres*



TAPS

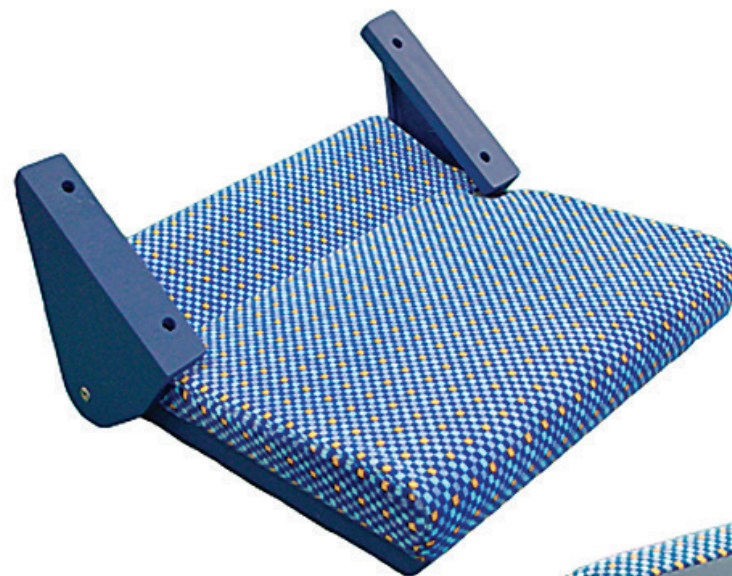

STADLER TIP-UP

*mounted with
or without a backrest*

TAPS



JUN 22 TIP-UP

*mounted with or
without a backrest*

TAPS

SLEEPING COACHES



WL BERTH

WL berths and couchettes for sleeping coaches.

- composite elements
- aluminium construction
- safety rails

Possible to arrange in the compartment
(upper, middle, bottom berth)

Patent protected safety rails for WL

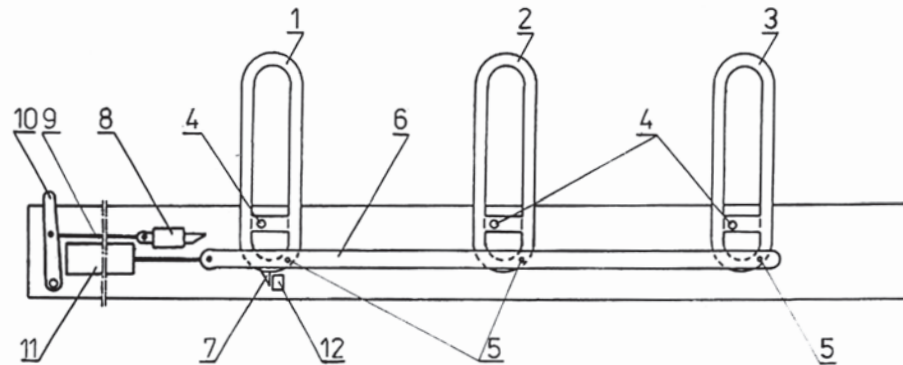

BERTHS

(delivered to PKP Intercity S.A.)

- Each coach contains 9 or 10 compartments
- 6 berths for each compartment: 2 top, 2 middle, 2 bottom
- During day trip, bottom berths can be folded to become couches and middle berths to become backrests

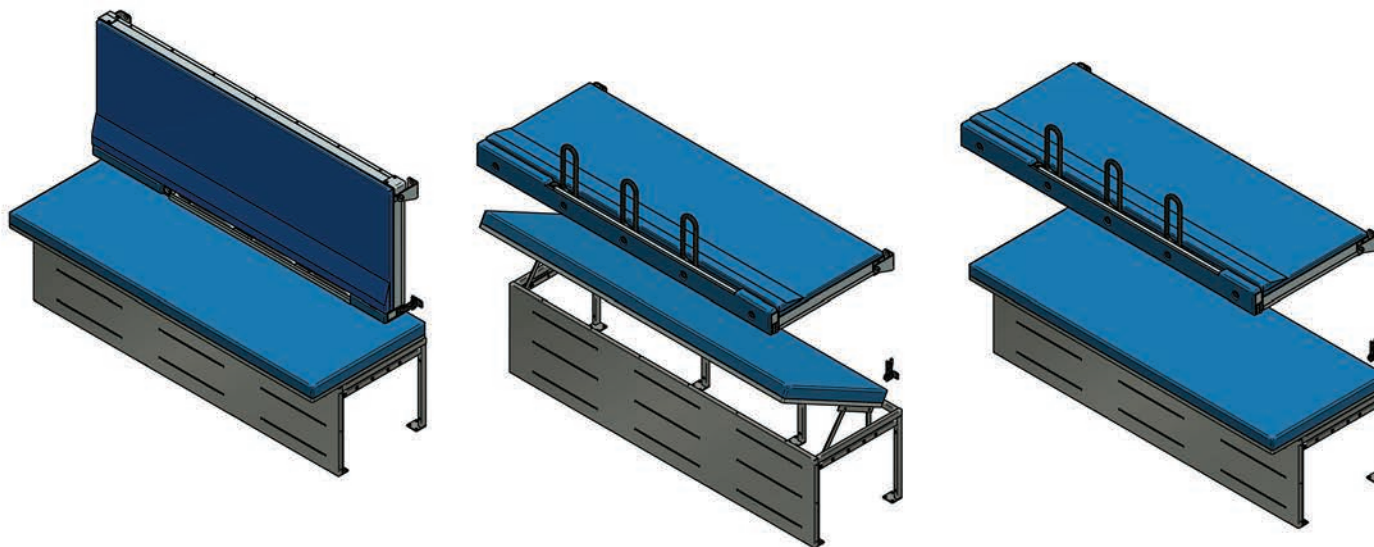

EuroNight

EuroNight is a solution for sleeping compartments.

It guarantees high comfort with:

- classic sleeping couches for night travels
- classic passenger seats for day travels

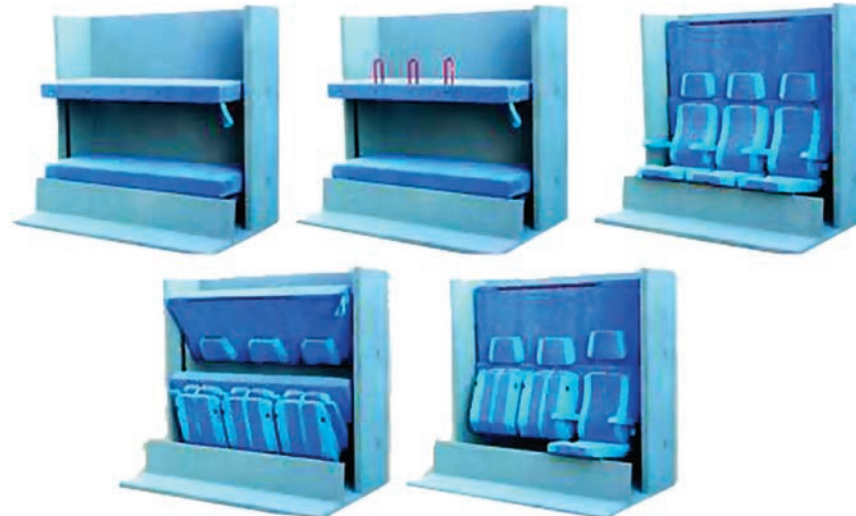



TAPS

REFERENCES

TAPS

IMPULS train (NEWAG S.A.)
with XCD KM
Koleje Mazowieckie – KM Sp. z o. o.



TAPS

IMPULS train (NEWAG S.A.)
with XCD KD
Koleje Dolnośląskie S.A.



TAPS

Non-compartment
coach (Pesa Bydgoszcz S.A.)
with TALIT 5 seats
PKP Intercity S.A.



TAPS

Non-compartment coach
(H. Cegielski S.A.)
with XCR S/1st class
PKP Intercity S.A.



TAPS

Non-compartment coach
(Pesa Bydgoszcz S.A.)
with XCR S/2nd class
PKP Intercity S.A.



TAPS

Compartment
(Pesa Bydgoszcz S.A.)
with XCI 3
PKP Intercity S.A.





POLAND

94-247 Lodz, Solec 3/5

Phone: +48 (42) 633 86 01

Fax: +48 (42) 650 09 96

e-mail: taps@taps.com.pl

www.taps.com.pl